

M36N-3E (φ 38.2 x 57mm)

Carbon Brush



Weight:230.0g

Applications

Printer

External Dimensions

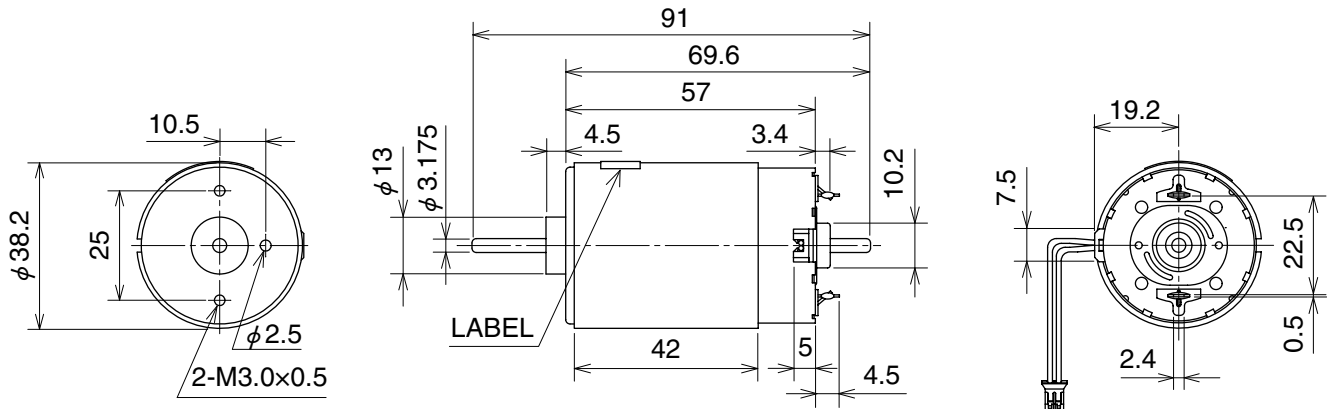

Unit: mm

Reference Characteristics

Model	Voltage		No Load		Rated Load		Rated Load		Starting Torque		Starting Current	Shaft length
	Operating	Rated	Speed	Current			Speed	Current				
	(V)	(V)	(min ⁻¹)	(mA)	(gf·cm)	(mN·m)	(min ⁻¹)	(mA)	(gf·cm)	(mN·m)	(mA)	(mm)
M36N-3E	12 to 27	24	3300	70	691	67.7	2378	1051	2473	242	3582	—*

※Characteristics and the shaft length can be customized.

Characteristics

